

# AmbiComp

## Input/Output Sandwich Module

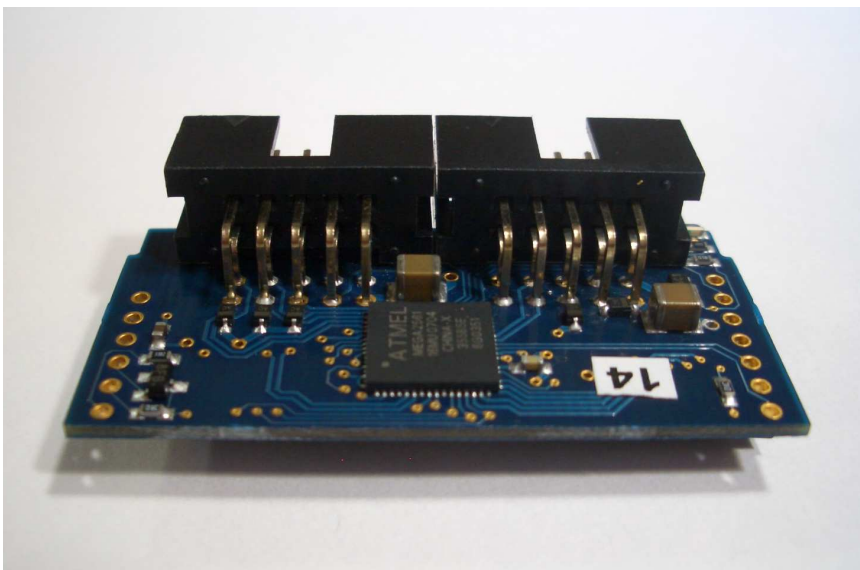

The I/O Sandwich Module is a component of the AmbiComp project and provides a series of programmable, general-purpose, analogous and digital interfaces. On the microcontroller residing on the I/O Sandwich Module runs the AmbiComp Virtual Machine (ACVM), which is capable of connecting with other components in order to set up a scalable AmbiComp network. Based on this network, small and medium-sized enterprises can develop their applications.



### Features

---

- Powerful RISC microcontroller
- Power supply via the backplane
- Green and yellow LEDs to display module status
- Two ports for external devices, programmable as input or output, analogous or digital
- AICU bus interface for direct communication with other modules
- Java Virtual Machine

## Specification

### Microcontroller:

The *I/O Sandwich Module* hosts an 8-bit RISC microcontroller, type AVR\* ATmega2561 from Atmel\* with a clock rate of 16 MHz.

### Software:

On the microcontroller, a compact hardware abstraction layer (BIOS) enables easy and efficient access to all interfaces of the sandwich module. With the help of this BIOS, the Ambi-Comp-specific Java Virtual Machine (ACVM) may run programs across all modules of a sandwich stack. Several of these stacks, which are dislocated, are connected by the ACVM through the use of a powerful routing procedure (SSR). (More infor-

mation on the ACVM and the program development for a sandwich stack in Java using an Eclipse plug-in can be found in the relevant data sheets.)

### Memory:

The microcontroller itself hosts 256 KiB flash for BIOS, ACVM and Java program, 8 KiB SRAM and 4 KiB EEPROM.

### Inout/Output:

The module provides two similar ports for external periphery. Each port carries the (switchable) power supply of 5 V and 8 single pins, which can be freely programmed as either

- digital input,
- analogous input, or
- digital output.

Pins 5 and 7 of each connector can also be programmed as

analogous outputs (Pulse Width Modulation, the frequency is SW-adjustable).

The pin layout of both connectors conforms to the project "Roboternetz" (RN):

Pin	Function
1	GPIO 0
2	GPIO 1
3	GPIO 2
4	GPIO 3
5	GPIO 4
6	GPIO 5 (PWM capable)
7	GPIO 6
8	GPIO 7 (PWM capable)
9	GND
10	Logic Voltage +5V

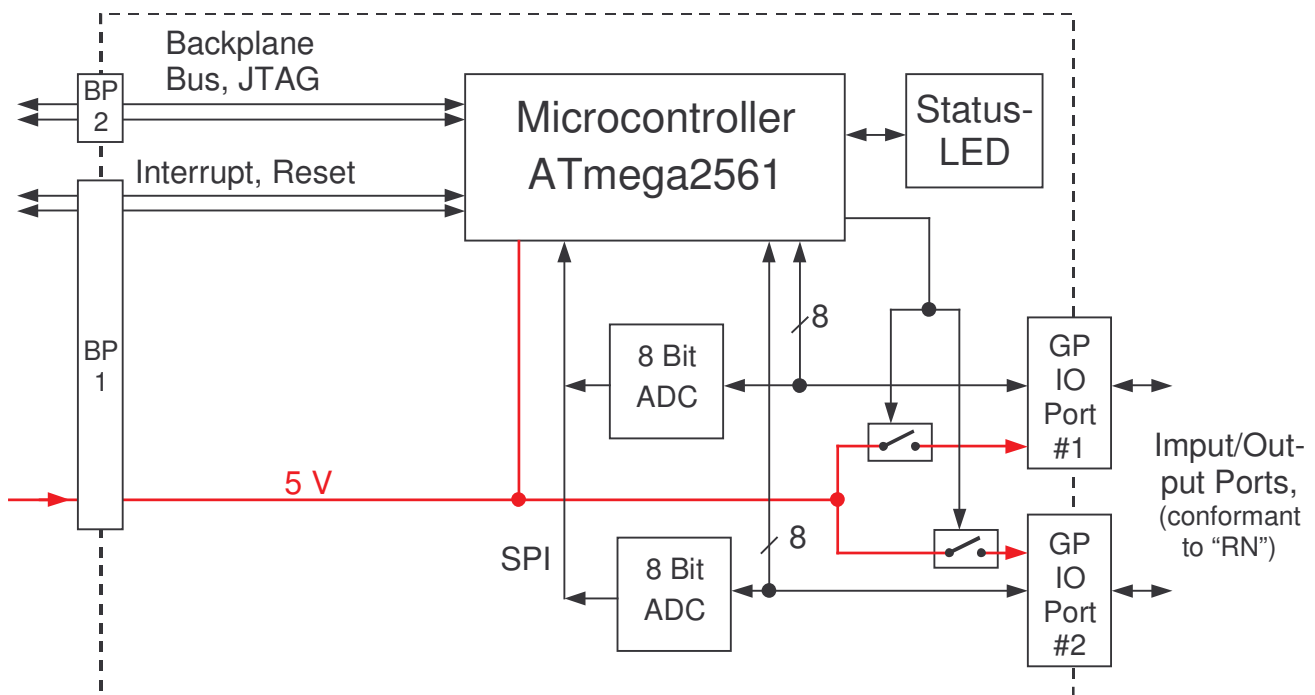

\* Atmel and AVR are registered trademarks of Atmel Corporation, San Jose, California, or its subsidiaries.

### Backplane:

Via an AmbiComp-specific interconnection scheme ("backplane"), the *I/O Sandwich Module* can be connected with other AmbiComp modules.



Detailed dimensioning and pin layout are contained in the data sheet "Sandwich Modules - General Information".

## Power Supply

---

The power is provided by other modules via the backplane, which has a primary power supply.

The current consumption is approximately 39 mA (at 3.3 V). The two status LEDs are not considered. Each of them consumes additional 10 mA.

## Mechanical Data

---

The module measures 49.8 mm x 24 mm. The height is 11 mm.

## Environmental Conditions

---

The *I/O Sandwich Module* is designed for indoor use. The operating temperature range is -10 to +70 °C.

The storage temperature range is -40 to +85 °C.

The module conforms to the RoHS requirements.

## Order Code

---

101 000 16